

intMPE

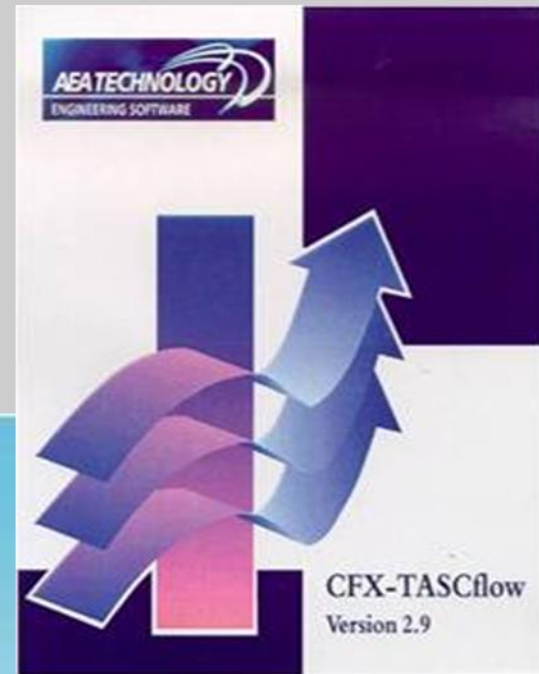

International Mineral Processing Equipment

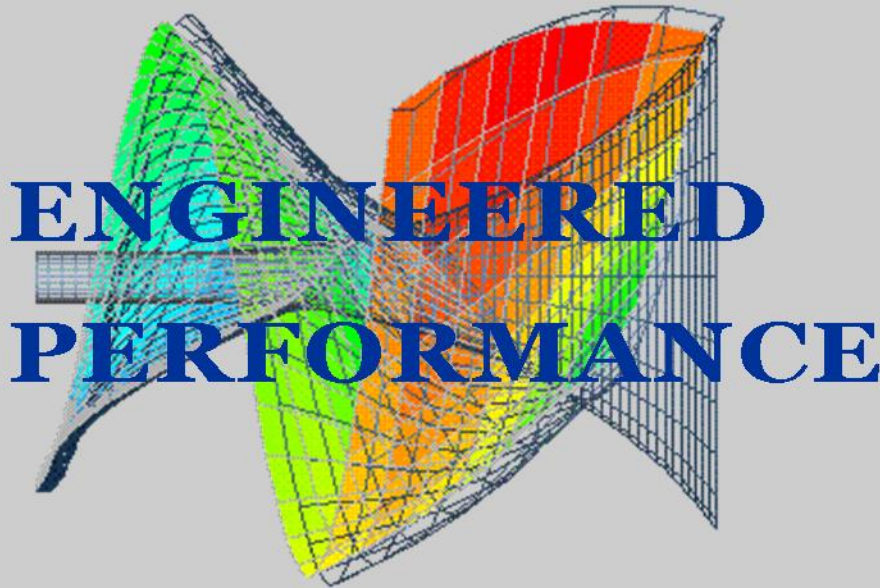

Industrial Series

API-610 & ANSI B73.1M

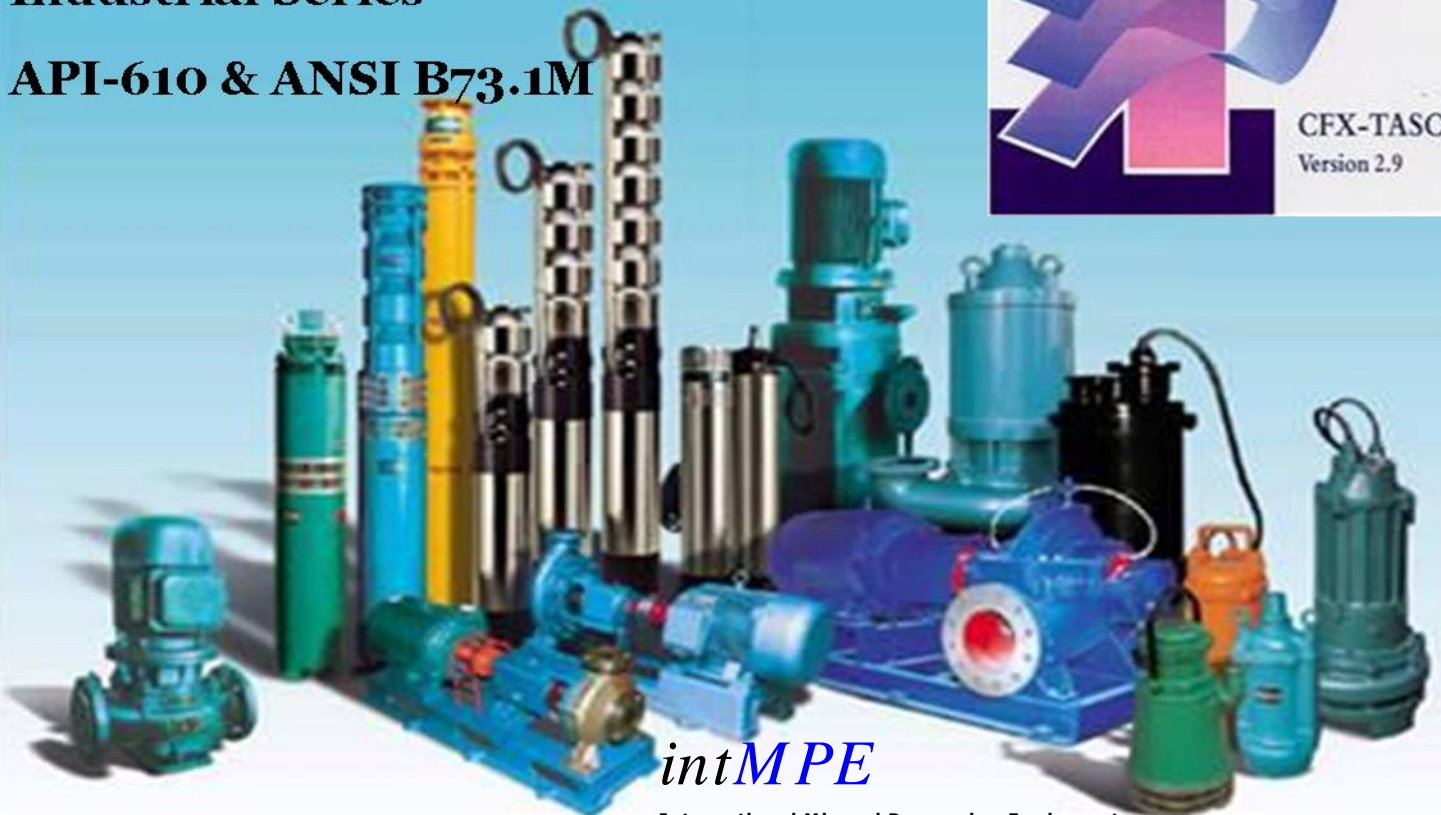

intMPE

International Mineral Processing Equipment
A Division of Canamera Enterprises Inc.



Fields of Application

For handling all kinds of pulps not liable to plait, as well as stock suspensions up to 5 % bone dry.

This pump is used in the chemical and process engineering industries, paper and pulp industries, sugar, food and beverages industries, in flue gas desulphurisation and coal upgrading and in the treatment of industrial effluents.

Design

Horizontal, radially split volute casing pump in back pull-out design, with impeller adapted to meet application requirements, single-flow, single-stage. Vertical mounting "L" optional.

Special Features

- Reinforced, axially adjustable bearing assembly on all pumps
- Shaft seal: mechanical seal integrated into the casing cover, or gland packing
- Even cast iron pumps are supplied with pump internals (impeller and wear plate) made of wear-resistant ERN (nickel cast iron)

Certification

Certified quality management ISO 9001.

Materials

Part No.	Description	Material variant				
		GN	C ₂	GC ₂	H	GH
101	Pump casing	JL1040 ¹⁾	Noridur 1.4593	JL1040 ¹⁾	Norihard ²⁾	JL1040 ¹⁾
135.01	Wear plate, suction side	ERN	Noridur 1.4593	ERN	Norihard	Norihard
162	Suction cover	JL1040 ¹⁾	Noridur 1.4593	JL1040 ¹⁾	Norihard	Norihard
163	Discharge cover	JL1040 ¹⁾	Noridur 1.4593	JL1040 ¹⁾	Norihard	Norihard
210	Shaft	C45+N	C45+N	C45+N	C45+N	C45+N
230	Impeller	ERN	Noridur 1.4593	Noridur 1.4593	Norihard	Norihard
330	Bearing bracket	JL1040 ¹⁾	JL1040 ¹⁾	JL1040 ¹⁾	JL1040 ¹⁾	JL1040 ¹⁾
344	Bearing bracket lantern	JL1040 ¹⁾	JL1040 ¹⁾	JL1040 ¹⁾	JL1040 ¹⁾	JL1040 ¹⁾
451.01	Stuffing box housing	-	Noridur 1.4593	JL1040 ¹⁾	JL1040 ¹⁾³⁾	JL1040 ¹⁾³⁾
524.01	Shaft protecting sleeve (packing)	1.4122 HV500	1.4539	1.4122 HV500	1.4122 HV500	1.4122 HV500
524.01	Shaft protecting sleeve (mech. seal)	1.4539	1.4539	1.4539	1.4539	1.4539
906	Impeller screw	C22+N	Noridur 1.4593	C22+N	C22+N	C22+N

1) GJL-250 to EN 1561

2) without auxiliary connection holes (pressure gauge connection and casing drain)

3) together with NORIHARD discharge cover

Designation

Type series _____ KWP K 100 - 250
 Impeller type _____
 Discharge nozzle DN _____
 Nominal impeller dia. _____
 Impeller types:
 K = channel-type impeller
 O = open multi-vane impeller
 F = free-flow impeller

Operating Data

	Standard sizes	Supplementary sizes
Pump sizes DN	40 up to 250	up to 800
Capacity Q	up to 1300 m ³ /h	11000 m ³ /h
Head H	up to 100 m	80 m
Operating pressure p	up to 10 bar	
Operating temperature t		
for H	from -10 to +120 °C	
for GN, GH, GC ₂	from -10 to +200 °C	
for C ₂	from -40 to +280 °C	

MPKWP-K intMPE NON CLOG SLUDGE PUMPS

n = 1160 1/min

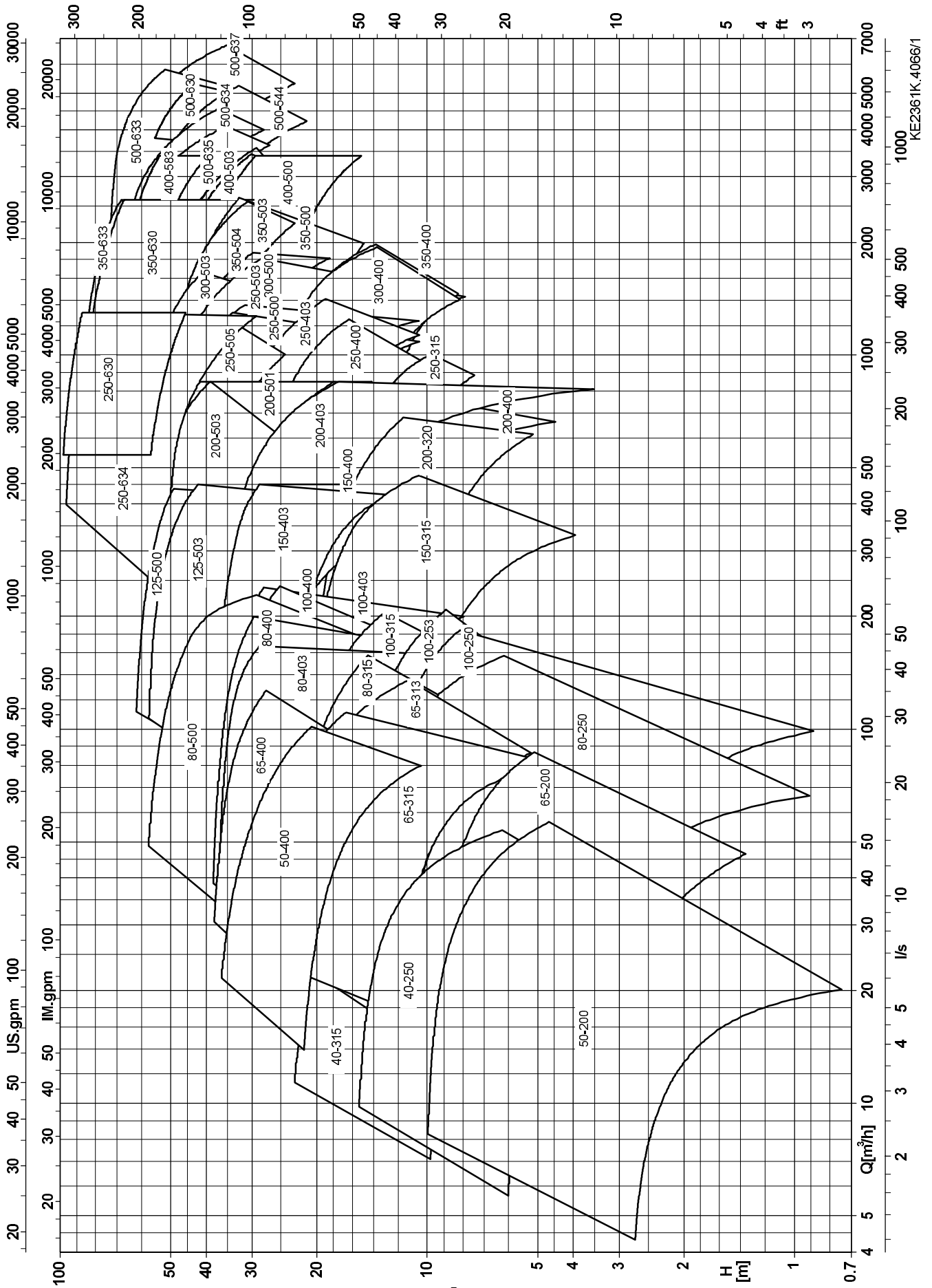

intMPE NON-CLOG PUMPS

Baureihe-Größe Type-Size Modèle	Tipo Serie Tipo	Nenn Drehzahl Nom. speed Vitesse nom.	Velocità di rotazione nom. Nominaal toerental Revoluciones nom.	Lauf rad- ϕ Impeller Dia. Diamètre de roue	ϕ Girante ϕ Waaier ϕ Rodete
250MPKWP-K630		1160 1/min			
Projekt Project Projet	Progetto Projekt Proyecto	Angebots-Nr. Project No. No. de l'offre	Offerta-No. Offertenr. Offerta-No.	Pos.-Nr. Item No. No. de pos.	Pos.-Nr. Positiën. Pos.-Nr.

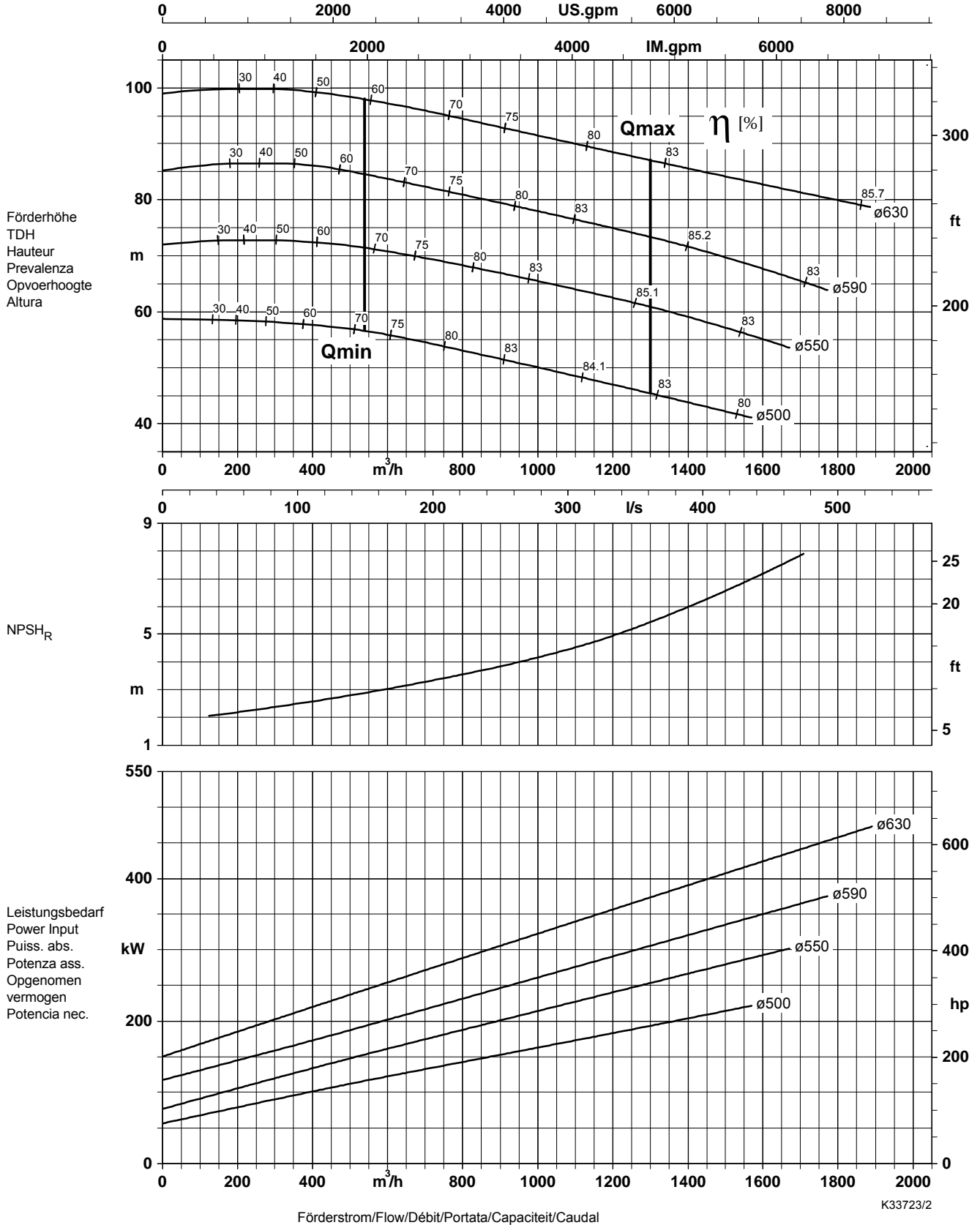

Lauf rad austrittsbreite/Impeller outlet width/Largeur à la sortie de la roue 86 x 100 mm
 Luce della girante/Waaier uittred breedte/Anchura de salida rodete 86 x 100 mm

MPKWP-K intMPE NON CLOG SLUDGE PUMPS

n = 1750 1/min

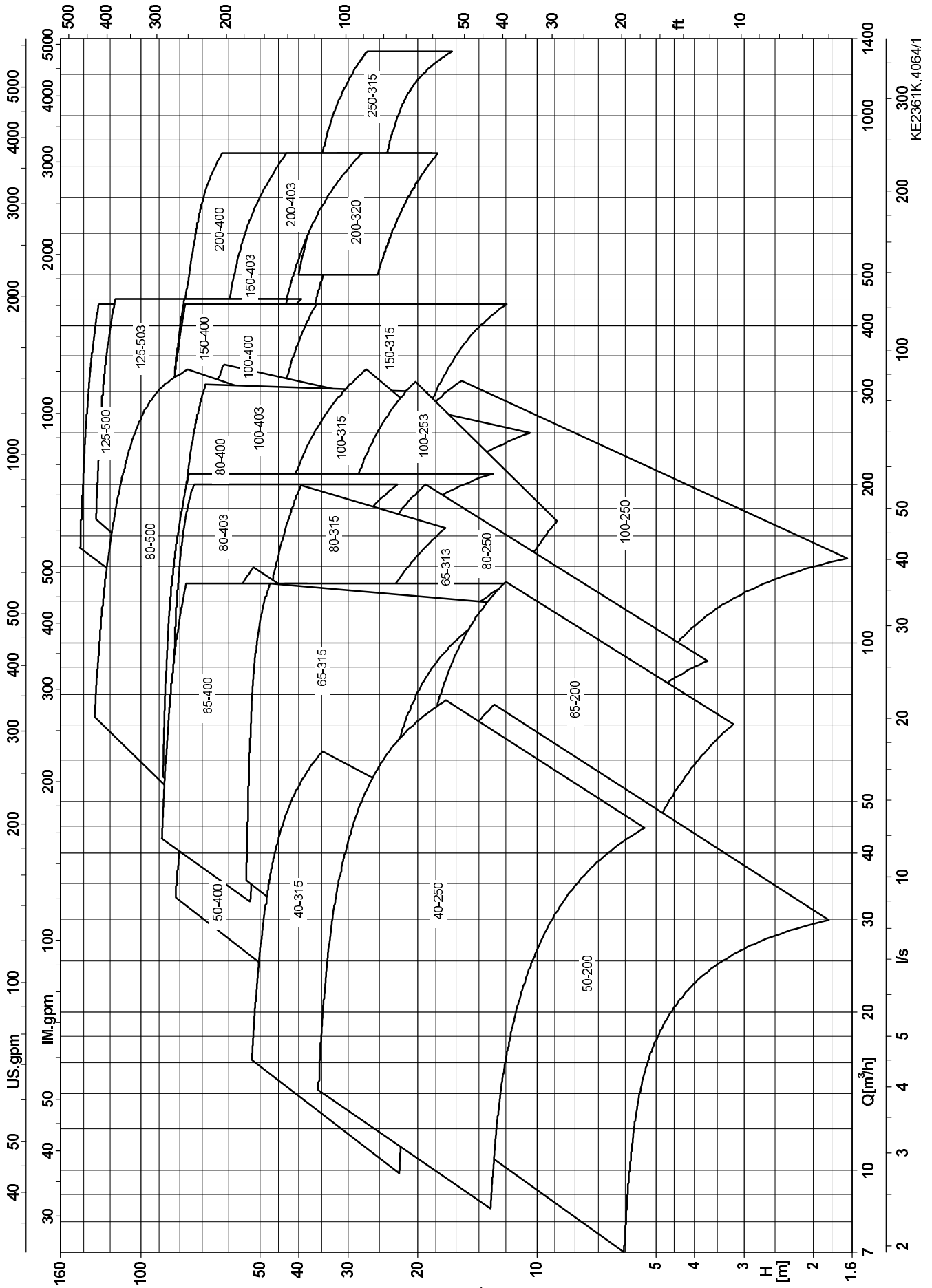

Design Features

Flange design in accordance with DIN/EN up to PN 16; other flange designs are possible.

Shaft not in contact with the medium handled (dry shaft); therefore no special materials required.

Back vanes for reduced axial thrust and shaft seal balancing.

All mechanical seals integrated in the casing cover with conical seal chamber (A-type cover), therefore improved internal circulation, automatic venting and dead-end operation possible.

Rotor and bearings are dimensioned for a shaft deflection at the shaft seal below 0.05 mm and a bearing life of more than 17 500 operating hours.

On request, pump casing is available with inspection hole.

Safe design of all pressure-retaining components due to quality casting with corrosion/wear allowance.

High efficiencies in the case of channel-type impeller design; impeller with front vanes and diagonal gap.

Pump casing with suction-side wear plate in wear-resistant diagonal gap design.

Due to the back pull-out design, the casing may remain in the pipeline when the pump is dismantled.

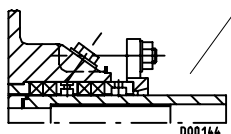

Pump version with gland packing and special discharge cover.

Jacking screws facilitate dismantling.

Use of existing modular design components ensures small stock of spare parts and fast delivery.

Cylindrical roller bearing as movable bearing permits easy assembly and compensates possible thermal expansion of the shaft.

Constant-level oiler ensures constant lubrication of the bearings.

Reinforced adjustable bearing assembly.

Rigid and stable support foot ensures that even in the case of high external forces the shaft is only slightly displaced in the coupling area.

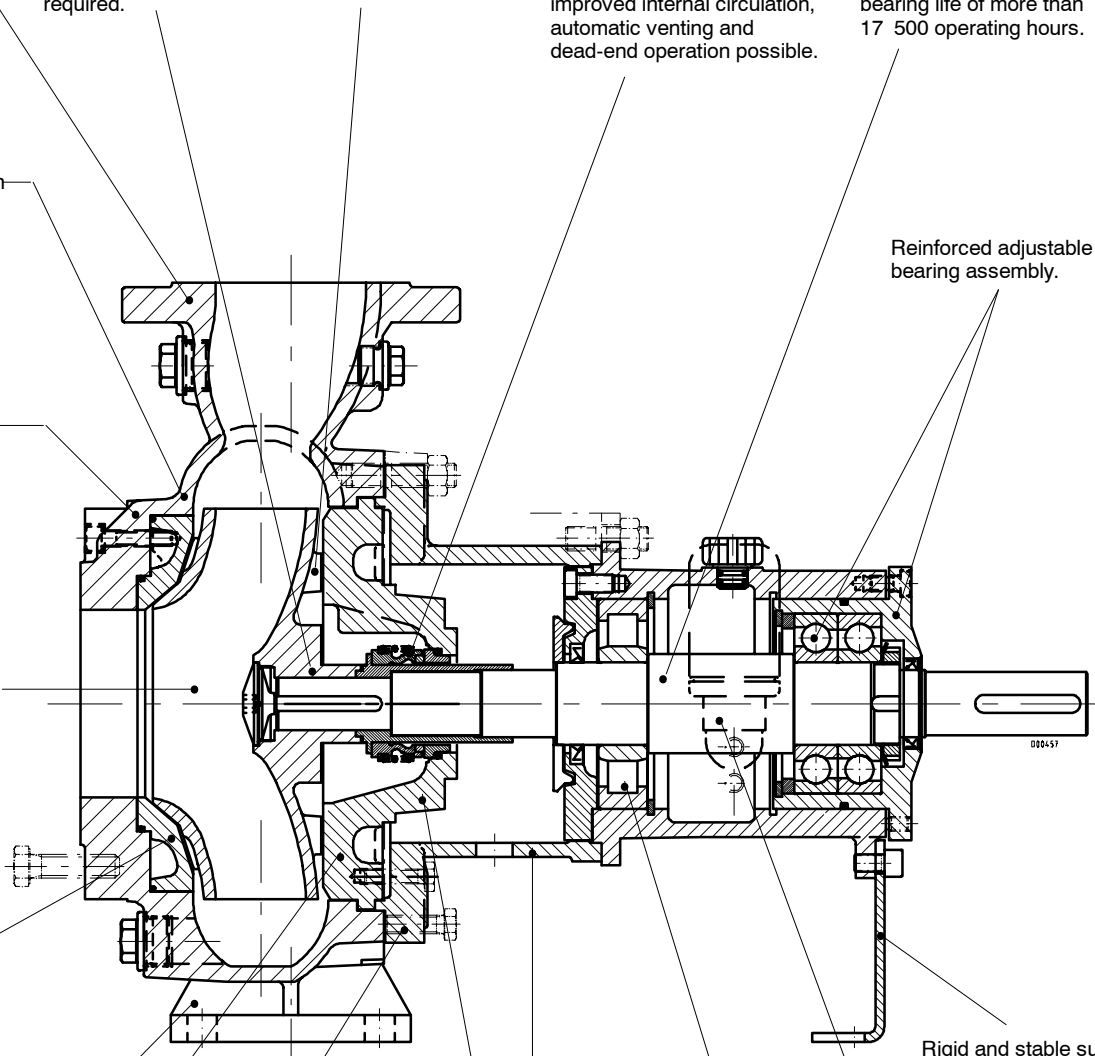

intMPE MPKWP NON CLOG SLUDGE HANDLING PUMPS

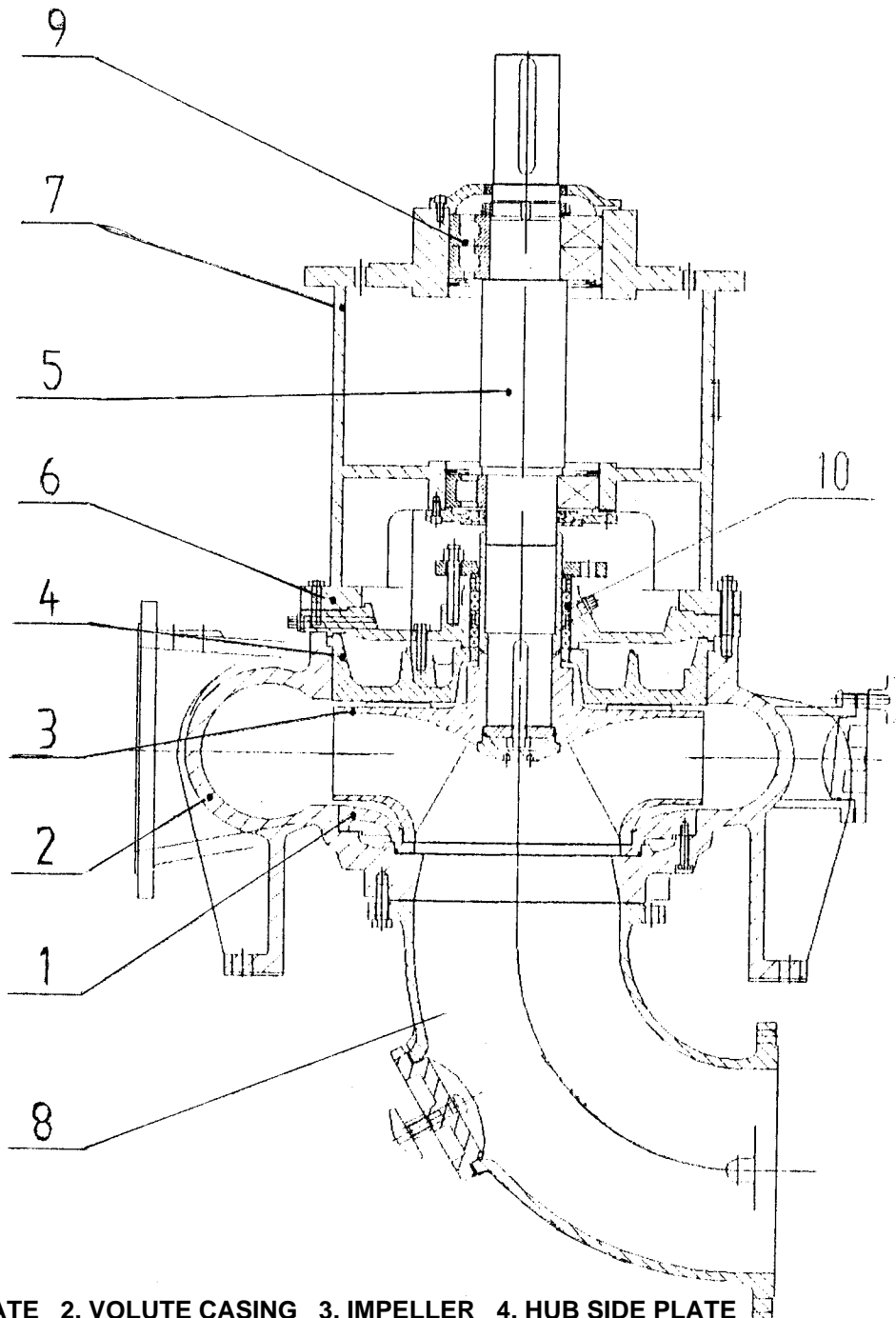

1. SUCTION PLATE 2. VOLUTE CASING 3. IMPELLER 4. HUB SIDE PLATE
5. SHAFT 6. STUFFING BOX 7. BEARING HOUSING 8. SUCTION ELBOW
9. BEARING 10. PACKING SYSTEM

Technical Data

Standard Pump Sizes

	Unit	Pump sizes																																				
		P03ax								P04ax								P05ax								P06x												
Bearing bracket		15	34	-	46	-	50	-	54	28	54	46	15	15	15	42	15	34	-	44	60	-	28	54	46	15	50	20	-	88	64	88	20	50	21	80	40	103
Impeller outlet width K	mm	260	209	-	209	-	260	-	260	320	320	408	-	320	260	-	260	320	408	-	320	260	-	260	320	404	404	404	404	320	404	320	504	504	509	403	404	324
Max. impeller dia.	mm	170	120	-	145	-	170	-	170	230	230	330	-	230	180	-	180	230	330	-	260	180	-	180	230	280	280	280	280	260	320	257	380	350	320	320	285	
Min. impeller dia.	mm	-	30	-	30	-	36	-	36	-	25	-	-	-	50	-	260	-	-	-	-	-	-	-	28	-	35	-	65	-	-	-	-	-	-	78	-	-
Impeller outlet width O	mm	-	209	-	209	-	260	-	260	-	320	-	-	-	260	-	260	-	-	-	-	-	-	404	-	404	-	-	320	-	-	-	-	-	-	404	-	-
Max. impeller dia.	mm	-	160	-	160	-	170	-	170	-	230	-	-	-	180	-	180	-	-	-	-	-	-	280	-	280	-	-	260	-	-	-	-	-	-	320	-	-
Min. impeller dia.	mm	-	45	-	55	-	60	-	60	-	-	-	-	-	70	-	-	-	-	-	-	-	-	-	-	-	-	-	90	-	-	-	-	-	-	-	-	
Free impeller passage F	mm	-	209	-	209	-	260	-	260	-	-	-	-	-	260	-	-	-	-	-	-	-	-	-	-	-	-	-	320	-	-	-	-	-	-	-	-	
Max. impeller dia.	mm	-	130	-	130	-	145	-	170	-	-	-	-	-	180	-	-	-	-	-	-	-	-	-	-	-	-	-	260	-	-	-	-	-	-	-	-	
Min. impeller dia.	mm	-	33	-	33	-	42	-	42	-	-	-	-	-	53	-	-	-	-	-	-	-	-	-	-	-	-	-	53	-	-	-	-	-	-	-	-	
in stuffing box housing	mm	-	45	-	45	-	55	-	55	-	-	-	-	-	65	-	-	-	-	-	-	-	-	-	-	-	-	-	65	-	-	-	-	-	-	-	-	
at pump side	mm	-	45	-	45	-	55	-	55	-	-	-	-	-	65	-	-	-	-	-	-	-	-	-	-	-	-	-	65	-	-	-	-	-	-	-	-	
bearings	mm	-	32	-	32	-	42	-	42	-	-	-	-	-	48	-	-	-	-	-	-	-	-	-	-	-	-	-	48	-	-	-	-	-	-	-	-	
at coupling	mm	-	45	-	45	-	55	-	55	-	-	-	-	-	70	-	-	-	-	-	-	-	-	-	-	-	-	-	70	-	-	-	-	-	-	-	-	
Packing	mm	-	45	-	45	-	55	-	55	-	-	-	-	-	80	-	-	-	-	-	-	-	-	-	-	-	-	-	80	-	-	-	-	-	-	-	-	
Mechanical seal	mm	-	45	-	45	-	55	-	55	-	-	-	-	-	80	-	-	-	-	-	-	-	-	-	-	-	-	-	80	-	-	-	-	-	-	-	-	
depending on make	mm	-	45	-	45	-	55	-	55	-	-	-	-	-	80	-	-	-	-	-	-	-	-	-	-	-	-	-	80	-	-	-	-	-	-	-	-	
Bearings																																						
pump side																																						
motor side																																						
Gland																																						
Bore dia.	mm																																					
Length	mm																																					
Packing ring dimensions	mm																																					
Number of packing rings	pcs.																																					
Lantern ring width	mm																																					
Clearance for removal	mm																																					
Pressure limits	bar																																					
Max. operating pressure	bar																																					
Max. test pressure	bar																																					
Temp. limits	°C																																					
Max. temperature of medium handled	°C																																					
see operating data	°C																																					
1.5 times the max. admissible operating pressure, min. 6 bar	bar																																					
see operating data	bar																																					
Drive																																						
P/n value (shaft C 45 N)																																						
0.03																																						
0.067																																						
0.144																																						
0.235																																						

Supplementary Sizes

Unit	Pump sizes																																			
	P 08sx / P 10ax / P 12sx					P 10ax / P 12sx / P 16ax					P 16ax / P 20sx																									
Bearing bracket	75	75	40	107	75	85	50	70	107	70	100	110	100	130	145	95	72	140	90	155	155	105	120	162	115	144	142	123	85	75	123	210	135	144	187	210
Impeller outlet width K	504	504	504	409	409	504	504	630	630	409	504	504	408	508	508	508	507	630	630	508	508	538	600	730	730	590	636	636	636	636	636	736	780	830	800	870
Max. impeller dia.	400	400	400	338	340	400	400	436	500	480	320	400	420	330	390	472	460	500	500	430	445	496	550	630	630	495	528	534	554	565	540	664	718	710	731	800
Min. impeller dia.	P 08sx: 80; P 10ax: 100; P 12sx: 120; P 16ax: 158; P 20sx: 198																																			
in stuffing box housing	P 08sx: 80; P 10ax: 120; P 12sx: 120; P 16ax: 160; P 20sx: 200																																			
at pump side	P 08sx: 95; P 10ax: 120; P 12sx: 120; P 16ax: 160/140; P 20sx: 200/190																																			
bearings	P 08sx: 75; P 10ax: 95; P 12sx: 110; P 16ax: 120; P 20sx: 145																																			
at coupling	P 08sx: 100; P 10ax: 120; P 12sx: 140; P 16ax: 170; P 20sx: 1)																																			
Shaft Packing	depending on make																																			
Mechanical seal	depending on make																																			
Bearings	P 08sx: NU 416; P 10ax: NU 324; P 12sx: NU 324; P 16ax: NU 292; P 20sx: NU 240																																			
at pump side	P 08sx: 2 x 7319 BG; P 10ax: 2 x 7324 BG; P 12sx: 2 x 7324 BG; P 16ax: NU 232/QJ 328; P 20sx: 29340/NU 238																																			
at motor side	P 08sx: 103; P 10ax: 103; P 12sx: 108; P 16ax: 130; P 20sx: 1)																																			
Gland Bore dia.	P 08sx: 132; P 10ax: 152; P 12sx: 172; P 16ax: 210; P 20sx: 1)																																			
Length	P 08sx: 16 x 16; P 10ax: 16 x 16; P 12sx: 16 x 16; P 16ax: 20 x 20; P 20sx: 1)																																			
Packing ring dimensions	4																																			
Number of packing rings	P 08sx: 30; P 10ax: 30; P 12sx: 30; P 16ax: 25; P 20sx: 1)																																			
Lantern ring width	P 08sx: 105; P 10ax: 105; P 12sx: 105; P 16ax: 25; P 20sx: 1)																																			
Clearance for removal	see operating data																																			
Pressure Max. operating pressure limits	1.5 times the max. admissible operating pressure, min. 6 bar																																			
Max. test pressure	see operating data																																			
Temp. limits	see operating data																																			
Max. temperature of medium handled	P 08sx: 0.458; P 10ax: 0.91; P 12sx: 1.75; P 16ax: 2.0; P 20sx: 1)																																			
Drive P/n value (shaft C 45 N)	1) Data on request.																																			

Pump Sizes

Dis-charge nozzle	Nominal impeller dia.																					
	200/201			250/251/253			315/311 313/320			400/403		500/501/ 503 504/505		544	583	630/633 634/635 637		710/ 713	803	813	823	923
	Impeller type																					
	K	F	O	K	F	O	K	F	O	K	O	K	K	K	K	K	K	K	K	K	K	
40				x			x					x										
50	x	x	x									x										
65	x	x										x	x									
80				x	x	x	x	x				x	x									
100				x	x	x	x					x	x									
125																						
150							x	x	x			x										
200							x	x				x	x									
250							x					x						x				
300												x										
350												x						x				
400												x						x				
500																		x				
600																		x	x			
700																		x	x			

Flanges

Suction flanges up to DN 350 are supplied with pocket holes for hex. head bolts to DIN 2501, PN 10/16; suction flanges DN 400 and above with through-holes to EN 1092-2, PN10. The discharge flange of sizes DN 40 to 150 is supplied in acc. with EN 1092-2, PN 16 (with through-holes), sizes DN 200 and above are supplied with flanges acc. to EN 1092-2, PN 10.

Casing

Radially split, consisting of pump casing with integrally cast suction and discharge nozzle as well as discharge cover. The discharge cover is available with integrally cast stuffing box housing or with bolted coolable stuffing box housing. The pump casing is available with or without wear plate. From pump size 400-710 onwards the suction nozzle is integrally cast on a separate suction cover.

Gland packing:

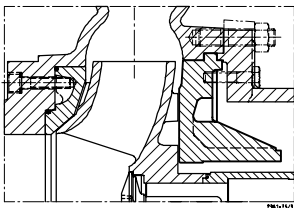

Discharge cover with integrally cast stuffing box housing (casing design 2)
Material variants: GN, GC₂, C₂

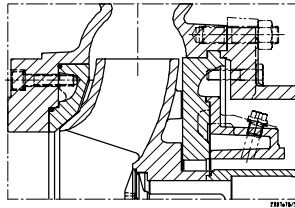

Discharge cover with bolted coolable stuffing box housing (casing design 3)
Material variants: GH, H

Mechanical seal:

Discharge cover with conical seal chamber (A-type cover)
Material variants: GN, GC₂, C₂, GH, H

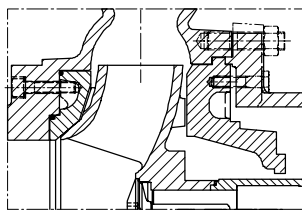

Shaft Seal

Single-acting mechanical seal in conical seal chamber, therefore improved internal circulation; automatic venting and dead-end operation possible. Gland packing variant available with barrier liquid /flushing liquid connection.

Gland packing

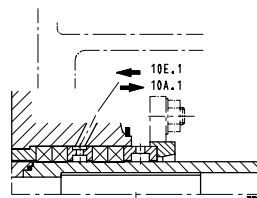

Standard version

Mechanical seal

"A" version (without spring-loaded ring cover), no external flushing required

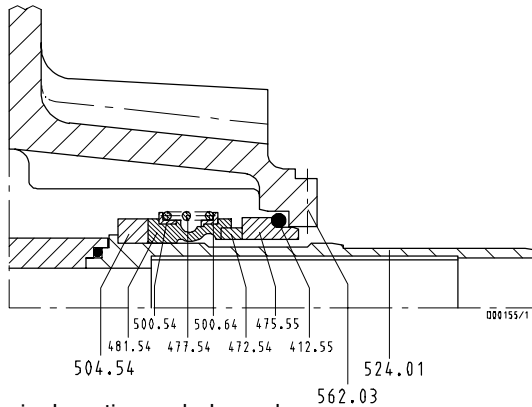

single-acting, unbalanced

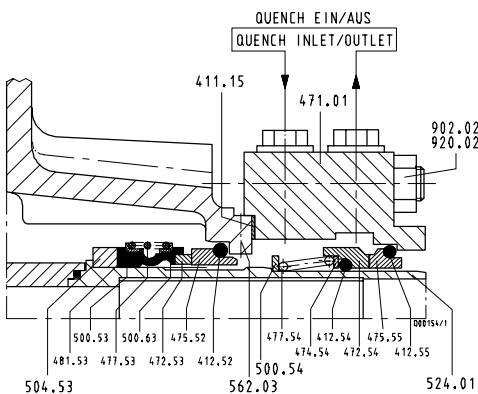

single-acting, unbalanced version with quench feed and additional single-acting mechanical seal (tandem arrangement)

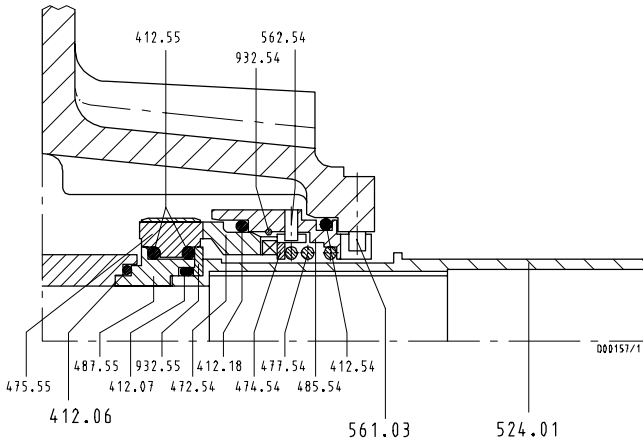

single-acting, balanced, stationary

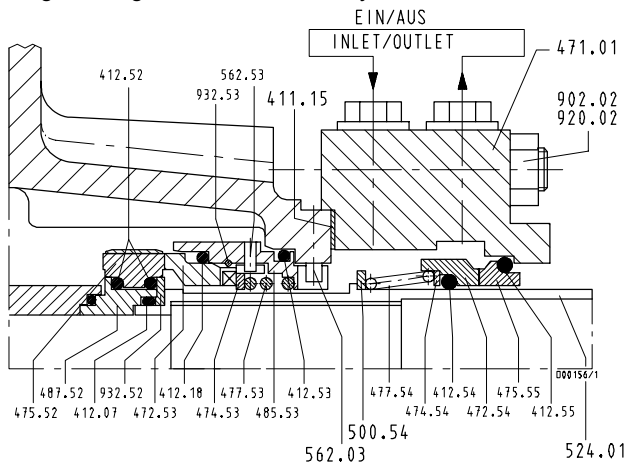

single-acting, balanced, stationary version with quench feed and additional single-acting mechanical seal (tandem arrangement)

Acceptance Tests / Guarantees

Each pump is subjected to a functional test, and its duty point is guaranteed according to ISO 9906/2A.

The following acceptance tests may be performed and certified at extra charge:

Performance test ISO 9906/2A:

1 measuring point / 5 measuring points

Performance test ISO 9906/1:

5 measuring points (refer to individual performance curve)

NPSH test 1 measuring point / 5 measuring points

If $Q < 0.3 Q_{opt}$, measuring the NPSH value is difficult, and the NPSH value cannot be certified. The value given in the individual performance curves can be fully used, however.

Coating and Preservation

acc. to KSB standard AN 1865

KWP (GN, GH, GC₂, H)

R 1 1 1 W

KWP (C₂)

N 0 1 1 U

Treatment of unmachined parts

Coating - wetted parts

Coating - baseplate and bearing bracket

Coating - motor

Preservation

N = reaction primer, wetted parts without last coating (internal and external)

R = reaction primer

1 = synthetic enamel RAL 5002, ultramarine blue

0 = without top coat

W = rinsed with water repellent, bright parts made of materials liable to rust with protective coating

U = untreated, bright parts made of materials liable to rust with protective coating

Recommended Spare Parts Stock for 2 Years' Operation

Part No.	Description	Number of pumps (including stand-by pumps)							
		2	3	4	5	6	8	10 and more	
135.01	Wear plate, suction side	2	2	2	3	3	4	50 %	
210	Shaft with small parts	1	1	1	2	2	2	20 %	
230	Impeller	1	1	1	2	2	2	20 %	
320/321	Rolling element bearings (set)	1	1	2	2	2	3	25 %	
330	Bearing bracket, complete	-	-	-	-	-	1	2 pieces	
433 1)	Spring-loaded ring	2	3	4	5	6	7	90 %	
	Seat ring	2	3	4	5	6	7	90 %	
	Secondary seal rings	2	3	4	5	7	9	100 %	
	Spring	1	1	1	1	2	2	20 %	
456 1)	Neck bush	1	1	2	2	2	3	30 %	
458 1)	Lantern ring	1	1	2	2	2	3	30 %	
	Set of gaskets or O-rings	4	6	8	8	9	12	150 %	
461 1)	Gland packing (4 rings)	4	4	6	6	6	8	100 %	
524	Shaft protecting sleeve	2	2	2	3	3	4	50 %	

1) if fitted

MPKWP

Dimensions

Pump sizes on bearing brackets P03x to P06x

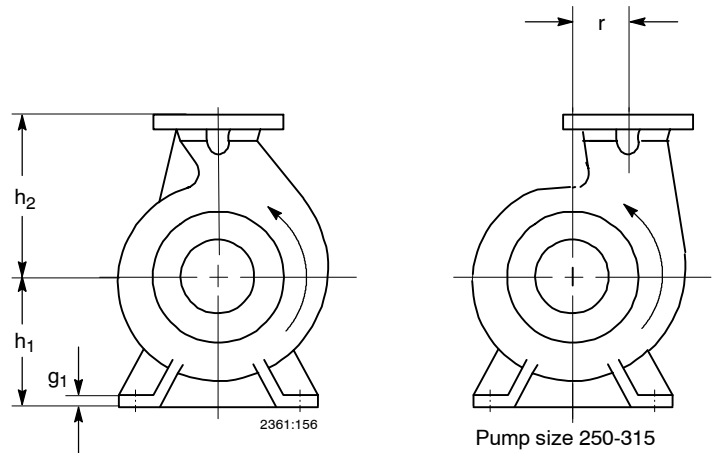
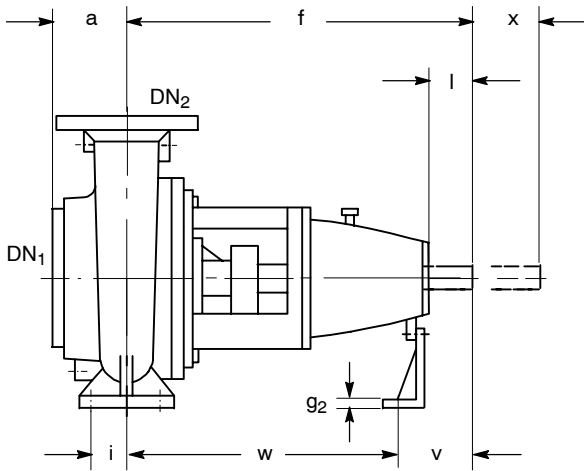

Pump size 250-315

x = back pull-out clearance (without removing the motor)

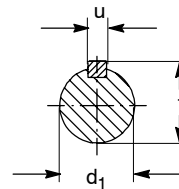
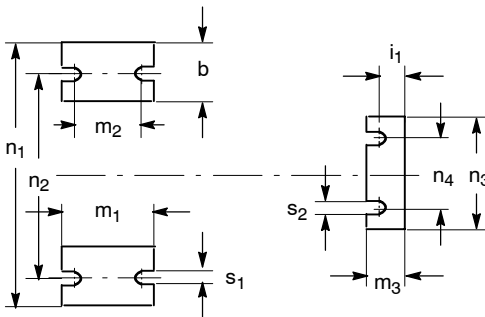

Shaft end and key to DIN 6885/p.1

Pump size	Bearing bracket	Pump dimensions																Shaft end					Foot dimensions							
		DN ₁	DN ₂	a	b	f	g ₁	g ₂	h ₁	h ₂	m ₁	m ₃	n ₁	n ₃	r	d	l	t	u	x	i	i ₁	m ₂	n ₂	n ₄	s ₁	s ₂	v	w	
40-250 40-315	P 03ax P 04ax	65 80	40 40	100 125	65 80	500 530	16 18	4 6	180 225	225 250	125 160	48 48	320 400	160 160	-	32 42	80 110	35,3 45,1	10 12	100 140	47,5 60	30 33	95 120	250 315	110 110	16 18	14 14	130 160	370 370	
50-200,201 50-400	P 03ax P 04ax	65 80	50 50	112 120	50 80	500 530	14 18	4 6	160 280	200 325	100 160	48 48	265 435	160 160	-	32 42	80 110	35,3 45,1	10 12	100 140	35 60	30 33	70 120	212 355	110 110	14 19	14 14	130 160	370 370	
65-200,201 65-315,311,313 65-400	P 03ax P 04ax P 04ax	80 80 80	65 65 65	125 140 140	65 80 80	500 530 530	16 18 18	4 6 6	180 225 280	225 280 355	125 160 160	48 48 48	320 400 435	160 160 160	-	32 42 42	80 110 110	35,3 45,1 45,1	10 12 12	120 120 120	47,5 60 60	30 33 33	95 120 120	250 315 355	110 110 110	14 18 19	14 14 14	130 160 160	370 370 370	
80-250,251 80-315,311 80-400,403 80-500	P 03ax P 04ax P 05ax P 06x	100 100 100 125	80 80 80 80	125 140 140 140	80 80 80 100	500 530 670 720	18 18 18 24	6 6 12 12	180 225 280 355	280 280 355 450	160 160 160 200	48 48 60 60	400 400 435 550	160 160 200 200	-	32 42 48 60	80 110 110 140	35,3 45,1 51,5 64,2	10 12 14 18	120 120 120 160	60 60 60 75	30 33 39 39	120 120 120 150	315 315 355 450	110 110 140 140	18 19 18 23	14 14 18 18	130 160 170 205	370 370 500 515	
100-250,251,253 100-315 100-400,403	P 04ax P 04ax P 05ax	125 125 125	100 100 100	140 140 140	80 80 100	530 530 670	18 18 20	6 6 12	225 250 280	280 315 355	160 180 200	48 48 60	400 400 500	160 160 200	-	42 48 48	110 110 110	45,1 45,1 51,5	12 12 14	140 140 160	60 60 75	33 33 39	120 120 150	315 315 400	110 110 140	18 18 23	14 14 18	160 160 170	370 370 500	
125-500,503	P 06x	150	125	160	100	720	24	12	355	450	200	60	550	200	-	60	140	64,2	18	160	75	39	150	450	140	23	18	205	515	
150-315,311 150-400	P 05ax P 05ax	150 150	150 150	180 160	100 100	670 670	22 22	12 12	315 315	400 450	200 200	60 60	550 550	200 200	-	48 48	110 110	51,5 51,5	14 14	160 160	75 75	39 39	150 150	450 450	140 140	23 23	18 18	170 170	500 500	
200-320 200-400,403	P 05ax P 06x	200 200	200 200	200 180	100 100	697 720	22 24	12 12	355 355	450 500	200 200	60 60	550 550	200 200	-	48 60	110 140	51,5 64,2	14 18	160 160	75 75	39 39	150 150	450 450	140 140	22 23	18 18	170 205	527 515	
250-315	P 06x	250	250	215	130	720	26	12	500	400	260	60	800	200	315	60	140	64,2	18	160	95	39	190	670	140	26	18	205	515	

Dimensions

Pump sizes on bearing brackets P08sx to P20sx

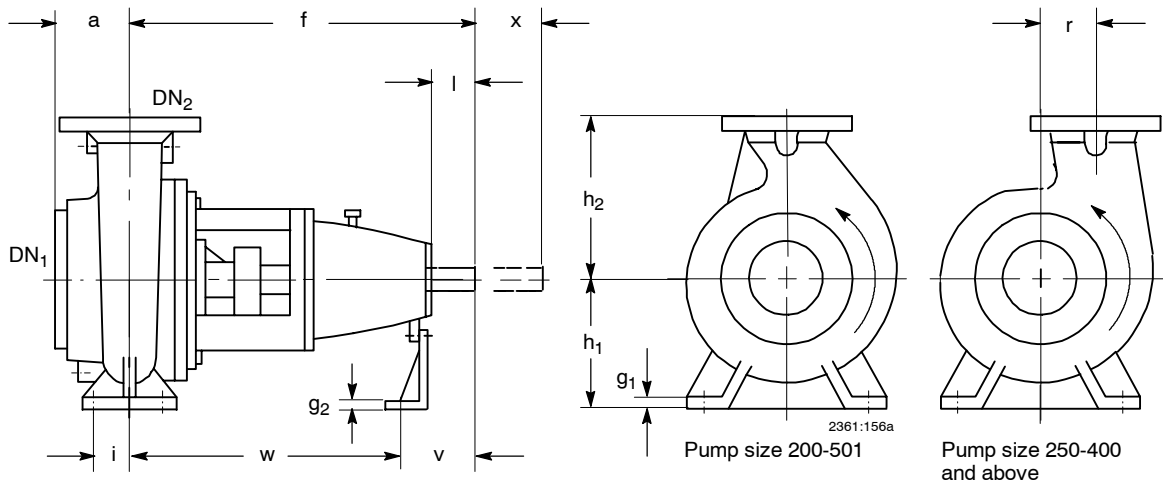

x = Back pull-out clearance (without removing the motor)

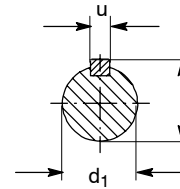
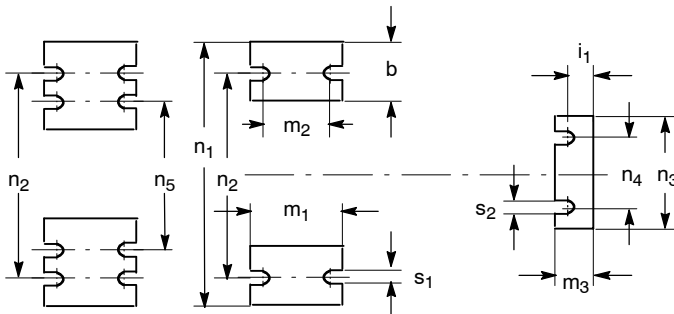

Shaft end and key to DIN 6885/p.1

Pump size	Bearing bracket	Pump dimensions														Foot dimensions							
		DN ₁	DN ₂	a	b	g ₁	g ₂	h ₁	h ₂	m ₁	m ₃	n ₁	n ₃	r	x	i	i ₁	m ₂	n ₂	n ₄	n ₅	s ₁	s ₂
200-500,501,503	P08sx/10ax/12sx	200	200	200	120	24	12	375	560	200	60	700	200	-	250	75	39	150	560	140	-	23	18
250-400,403	P08sx/10ax	250	250	180	130	26	12	425	375	260	60	800	200	300	315	95	39	190	670	140	-	26	18
250-500,503,505	P08sx/10ax/12sx	250	250	200	130	26	12	425	400	260	60	800	200	315	315	95	39	190	670	140	-	28	18
250-630,634	P08sx/10ax/12sx	250	250	200	150	32	12	500	450	260	60	900	200	400	315	95	39	190	750	140	-	26	18
300-400	P08sx/10ax	300	300	180	180	32	12	500	400	360	60	900	200	390	315	125	39	250	750	140	-	28	18
300-500,503	P08sx/10ax/12sx	300	300	200	130	26	12	450	450	260	60	800	200	315	315	95	39	190	670	140	-	28	18
350-400	P08sx/10ax	350	350	200	225	32	12	560	450	400	60	1080	200	395	315	150	39	300	1000	140	750	28	18
350-500,503,504	P08sx/10ax/12sx	350	350	290	225	32	12	560	500	400	60	1080	200	415	315	150	39	300	1000	140	750	28	18
350-630,633	P08sx/10ax/12sx	350	350	250	150	32	12	560	560	360	60	900	200	400	350	125	39	250	750	140	-	28	18
400-500,503	P08sx/10ax/12sx	400	400	260	250	40	16	670	500	400	85	1150	216	490	400	150	59	300	1040	140	800	39	18
400-533	P10ax/12sx	400	400	350	250	40	16	630	525	360	85	1150	216	475	400	125	50	250	1040	140	800	40	18
400-583	P10ax/12sx	400	400	390	250	40	16	700	540	400	85	1150	216	510	400	150	50	300	1040	140	800	40	18
400-710,713	P10ax/12sx/16ax	500	400	350	250	40	16	670	600	400	85	1150	216	480	350	150	59	300	1040	140	800	38	18
500-544	P10ax/12sx	500	500	425	250	40	30	800	630	400	125	1400	200	585	450	150	60	300	1290	140	1050	38	18
500-630,633,634	P10ax/12sx/16ax	500	500	375	250	40	16	750	630	400	85	1400	216	575	400	150	50	300	1290	140	1050	38	18
500-635,637	P10ax/12sx/16ax	500	500	375	250	40	16	750	630	400	85	1400	216	575	400	150	50	300	1290	140	1050	38	18
600-710	P12sx/16ax	600	600	500	250	40	18	900	750	400	80	1600	216	680	500	150	55	300	1490	140	1250	38	18
600-803,813,823	P 16ax/P 20sx 1)																						
700-923	P 20sx 1)																						

1) Dimensions on request

MPKWP

Dimensions

Pump sizes on bearing brackets P08sx to P20sx

Pump size	Pump dimensions					Foot dimensions									
	f					v					w				
	P08sx	P10ax	P12sx	P16ax	P20sx	P08sx	P10ax	P12sx	P16ax	P20sx	P08sx	P10ax	P12sx	P16ax	P20sx
200-500,501,503	970	1160	1160	-	-	220	410	410	-	-	750	750	750	-	-
250-400,403	1000	1190	-	-	-	220	410	-	-	-	780	780	-	-	-
250-500,503,505	1000	1190	1190	-	-	220	410	410	-	-	780	780	780	-	-
250-630,634	1000	1190	1190	-	-	220	410	410	-	-	780	780	780	-	-
300-400	1000	1190	-	-	-	220	410	-	-	-	780	780	-	-	-
300-500,503	1000	1190	1190	-	-	220	410	410	-	-	780	780	780	-	-
350-400	1000	1190	-	-	-	220	410	-	-	-	780	780	-	-	-
350-500,503,504	1000	1190	1190	-	-	220	410	410	-	-	780	780	780	-	-
350-630,633	1000	1190	1190	-	-	220	410	410	-	-	780	780	780	-	-
400-500,503	1000	1190	1190	1)	-	220	410	410	1)	-	780	790	790	1)	-
400-533	-	1175	1175	1)	-	-	450	450	1)	-	-	725	725	1)	-
400-583	-	1180	1180	1)	-	-	450	450	1)	-	-	730	730	1)	-
400-710,713	-	1205	1205	1)	-	-	425	425	1)	-	-	780	780	1)	-
500-544	-	1190	1190	-	-	-	435	435	-	-	-	755	755	-	-
500-630,633,634	-	1190	1190	-	-	-	440	440	-	-	-	750	750	-	-
500-635,637	-	1190	1190	-	-	-	440	440	-	-	-	750	750	-	-
600-710	-	-	1240	1)	-	-	-	450	1)	-	-	-	790	1)	-
600-803,813,823	-	-	-	1)	1)	-	-	-	1)	1)	-	-	-	1)	1)
700-923	-	-	-	-	1)	-	-	-	-	1)	-	-	-	-	1)

1) On request

Shaft end

Bearing bracket	d ₁	l	t	u
P 08sx	75	150	79.7	20
P 10ax	95	220	100.2	25
P 12sx	110	220	116.2	28
P 16ax	120	210	127.2	32
P 20sx	145	270	153	26

When ordering spare parts please always specify the type series/pump size, works No. (stamped on the name plate and on the suction nozzle flange), motor No. (serial No.), year of construction, quantity required, part No., description, material, medium handled, drawing no. and mode of dispatch.

Part No.	Description	Scope of supply
101	Pump casing	with joint ring 411.01 ¹⁾ /02 ¹⁾ /03 ¹⁾ /10, hex. head bolt 901.01, stud 902.01, screwed plug 903.01 ¹⁾ /02 ¹⁾ /03 ¹⁾ , hex. nut 920.01
135.01 4)	Wear plate (suction-side)	with joint ring 411.13, O-ring 412.05/75, hex. head bolt 901.03, socket head cap screw 914.05
163 2)	Discharge cover (A-cover)	with hex. head bolt 901.22
163 3)	Discharge cover (with integrally cast stuffing box housing)	with joint ring 411.16/17, drip plate 463.01, disc 550.01, stud 902.02, screwed plug 903.16/17, hex. nut 920.02
183	Support foot	with socket head cap screw 914.04, spring washer 930.01
210	Shaft	with keywayed nut 920.21, lockwasher 931.01, key 940.01/02
230	Impeller	with O-ring 412.06
320.02	Angular contact ball bearing	
322.01	Cylindrical roller bearing	
330	Bearing bracket	
330	Bearing bracket (complete)	with bearing cover 360.01, bearing carrier 382, gasket 400.01, joint ring 411.46, O-ring 412.02, radial shaft seal ring 421.01/02, support disc 550.23, constant-level oiler 638, vent plug 672, screwed plug 903.46, grub screw 904.01, socket head cap screw 914.01/02, circlip 932.01/03
344	Bearing bracket lantern	with forcing screw 901.31, stud 902.04, hex. nut 920.04
360.01	Bearing cover	with gasket 400.01, socket head cap screw 914.01
382	Bearing carrier	with O-ring 412.02, grub screw 904.01, socket head cap screw 914.02, circlip 932.03
421.01/02	Radial shaft seal ring	
451.01 1)	Stuffing box housing	with gasket 400.05, joint ring 411.16/17/18/19/26, drip plate 463.01, disc 550.01, stud 902.02, screwed plug 903.16/17/18/19, hex. nut 920.02
452.01 1)	Gland cover	
454.01 1)	Stuffing box ring, split	
456.01 1)	Neck bush	
458.01 1)	Lantern ring, split	
461.01 1)	Gland packing	
502.01 4)	Casing wear ring	
507.01	Thrower	
524.01	Shaft protecting sleeve	with O-ring 412.06
906	Impeller screw	with O-ring 412.03
99-9	Set of sealing elements	with gasket 400.01/02/03/04, joint ring 411.01/02/03/10/12/13/46, O-ring 412.02/03/05

1) if fitted

2) on pumps with mechanical seal

3) material variants GN, GN₁, GC₂, C₂ with packing

4) on 250-315 casing wear ring 502.01 instead of wear plate

Pumps on Bearing Brackets P 08sx, P 10ax and P 12sx

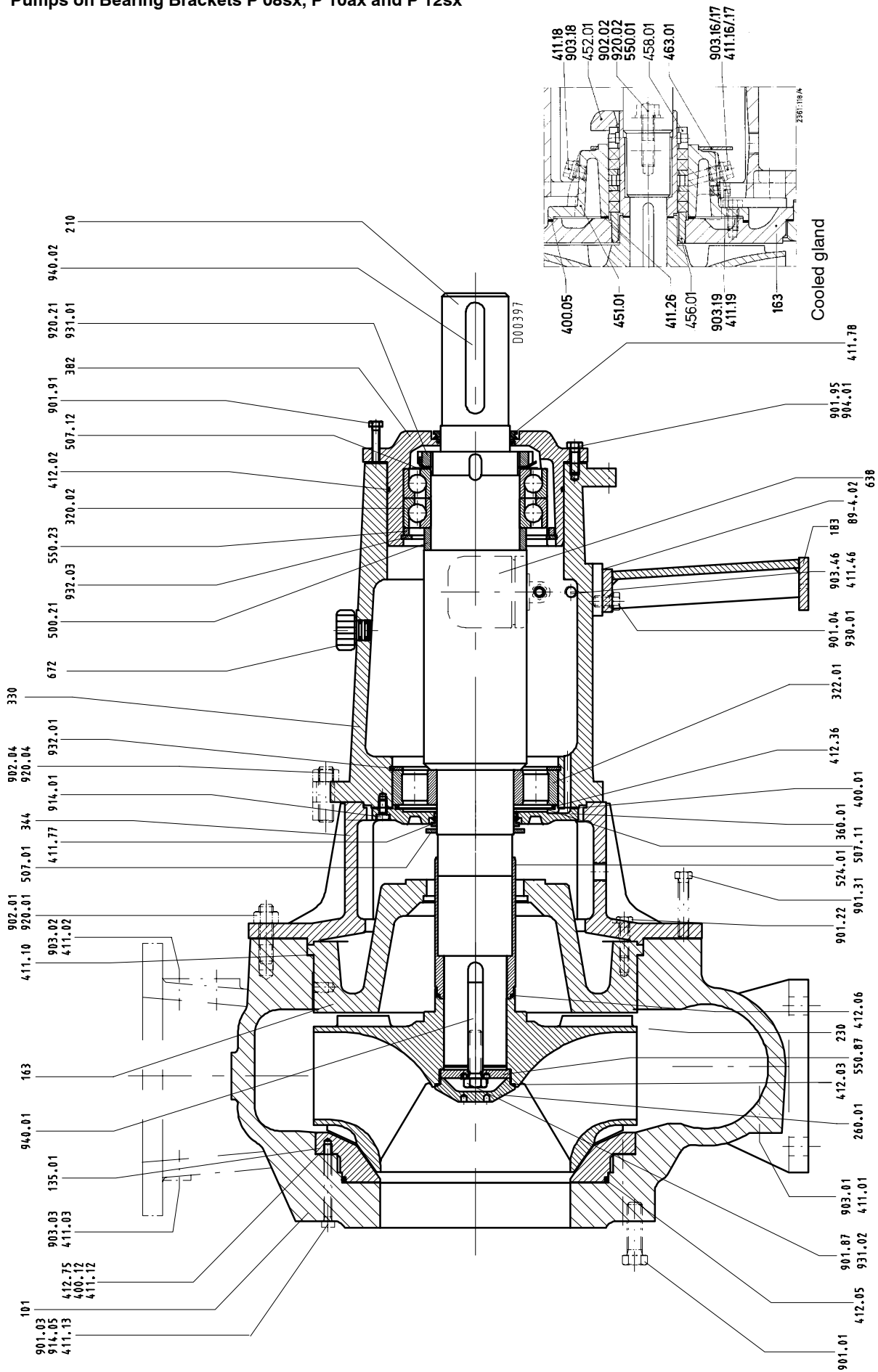

When ordering spare parts please always specify the type series/pump size, works No. (stamped on the name plate and on the suction nozzle flange), motor No. (serial No.), year of construction, quantity required, part No., description, material, medium handled, drawing No. and mode of dispatch.

Part No.	Description	Scope of supply
101	Pump casing	with joint ring 411.01 ¹⁾ /02 ¹⁾ /03 ¹⁾ /10, hex. head bolt 901.01, stud 902.01, screwed plug 903.01 ¹⁾ /02 ¹⁾ /03 ¹⁾ , hex. nut 920.01
135.01 2)	Wear plate (suction-side)	with joint ring 411.12/13, O-ring 412.05/75, hex. head bolt 901.03, socket head cap screw 914.05
163 3)	Discharge cover (A-cover)	with hex. head bolt 901.22
163	Discharge cover (with integrally cast stuffing box housing)	with joint ring 411.16/17, drip plate 463.01, disc 550.01, stud 902.02, screwed plug 903.16/17, hex. nut 920.02
183	Support foot	with shim 89-4.02, hex. head bolt 901.04, spring washer 930.01
210	Shaft	with ring 500.21, keywayed nut 920.21, lockwasher 931.01, key 940.01/02
230	Impeller	with O-ring 412.06
260.01	Impeller cap	with O-ring 412.03, disc 550.87, hex. head bolt 901.87, lockwasher 931.02
320.02	Angular contact ball bearing	
322.01	Cylindrical roller bearing	
330	Bearing bracket	
330	Bearing bracket (complete)	with bearing cover 360.01, gasket 400.01, joint ring 411.46/77/78, support disc 550.23, constant-level oiler 638, vent plug 672, hex. head bolt 901.91/95, screwed plug 903.46, socket head cap screw 914.01, circlip 932.01/03
344	Bearing bracket lantern	with hex. head bolt 901.22, forcing screw 901.31, stud 902.04, hex. nut 920.04
360.01	Bearing cover	with gasket 400.01, O-ring 412.36, disc 507.11, socket head cap screw 914.01
382	Bearing carrier	with O-ring 412.02, grub screw 904.01, hex. head bolt 901.95, circlip 932.03
411.77/78	V-ring	
451.01 1)	Stuffing box housing	with gasket 400.05, joint ring 411.16/17/18/19/26, drip plate 463.01, disc 550.01, stud 902.02, screwed plug 903.16/17/18/19, hex. nut 920.02
452.01 1)	Gland cover	
454.01 1)	Stuffing box ring, split	
456.01 1)	Neck bush	
458.01 1)	Lantern ring, split	
461.01 1)	Gland packing	
502.01	Casing wear ring 2)	
507.01	Thrower	
524.01	Shaft protecting sleeve	with O-ring 412.06
99-9	Set of sealing elements	with gasket 400.01/02/12, joint ring 411.01/02/03/12/13/46, O-ring 412.02/03/05/06

1) if fitted

2) on 300-400 and 350-500 casing wear ring instead of wear plate

3) on pumps with mechanical seal

MPKWP

Pumps on bearing bracket P 16 sx

Suction cover
part no. 162

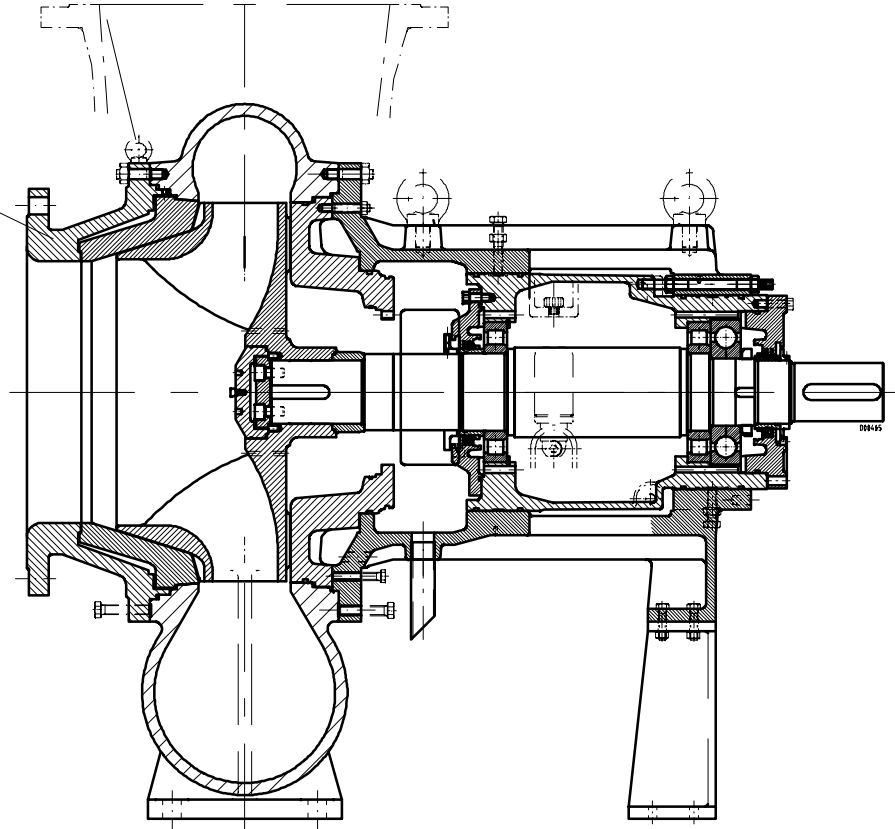

Pumps on bearing bracket P 20 sx

Suction cover
part no. 162

