

intMPE

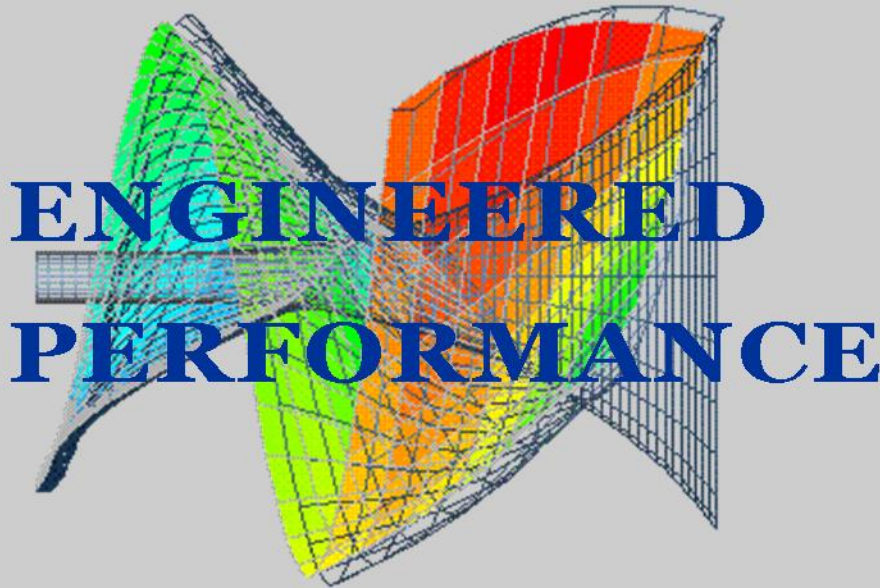

International Mineral Processing Equipment



Industrial Series

API-610 & ANSI B73.1M



intMPE

International Mineral Processing Equipment
A Division of Canamera Enterprises Inc.



intMPE PUMPS

700MPSPDJP Self-Priming Pumps



intMPE Process Pumps

MPSPDJP intMPE self-priming pumps are based on US proven technology and is available in cast stainless, iron and steel materials.

MPSPDJP has been developed to pumps are suitable to pump without priming clear water or corrosive liquids similar to clear water in field ponds with some solids. The intMPE MPSPDJP pumps can be **rated for fire fighting service.**

Many of our pumps are also used in irrigation and drainage, chemical and pharmaceuticals. MPSPDJP is a horizontal single stage centrifugal pump.

Performance

- **Suction lifts to 25 feet (7.6m)**
- **Temperature to 105 °C**
- **Capacity to 4000GPM (900m³/h)**
- **Head to 120 feet (37m)**

Service

- ▲ **Industry**
- ▲ **Farmland**
- ▲ **Fire fighting**
- ▲ **Irrigation and drainage**

- ▲ **Chemical and pharmaceutical**

Large capacity priming chamber

For reliable priming and repriming

Heavy duty power end

For extended life in toughest services

External impeller adjustment

Easily renews optimum hydraulic performance

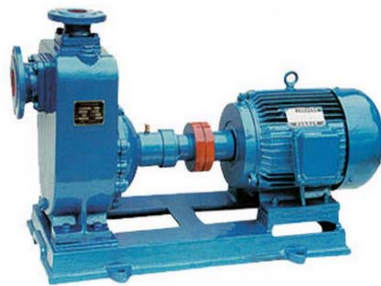

Trimmable impeller

Permits most efficient use of motor power

Non-clog impeller

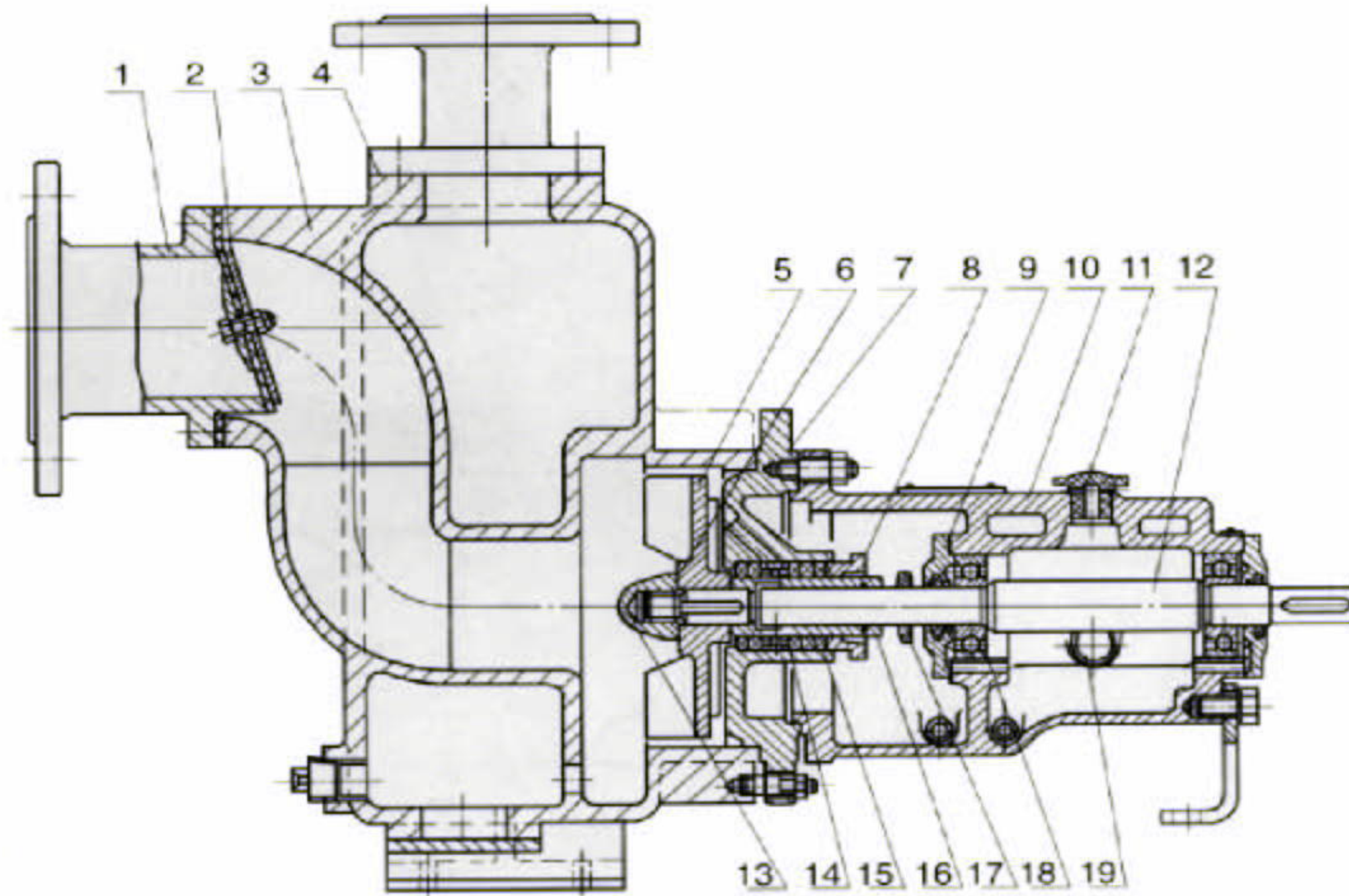

- | | | |
|-----------------------|---------------------|-------------------------|
| 1. Inlet Pipe | 2. Check Valve | 3. Volute Casing |
| 4. Pipe | 5. Impeller | 6. Lock Washer |
| 7. Stuffing Box Cover | 8. Gland | 9. Bearing Cover |
| 10. Frame | 11. Oil Filler Plug | 12. Shaft |
| 13. Impeller Nut | 14. Lantern Ring | 15. Soft Paking |
| 16. Sleeve | 17. Water Thrower | 18. Radial Ball Bearing |
| 19. Oil Level Gauge | | |

